

P_N [kW]

Ratio Ratio i	Velocidad De Entrada Input speed	Tamaño / Size A (mm)					
		2CV-A- 160	2CV-A- 200	2CV-N- 250	2CV-N- 320	2CV-N- 400	2CV-N- 500
6,3	750	22	56	61	130	250	462
	1000	28	74	82	175	340	610
	1500	42	112	109	265	515	918
8	750	22	30	48	125	207	370
	1000	28	40	64	150	275	482
	1500	42	60	96	210	413	721
10	750	18	30	37	109	165	295
	1000	23	40	50	128	220	395
	1500	34	60	75	169	330	578
12,5	750	14	27	30	92	132	240
	1000	20	36	40	109	176	310
	1500	27	55	61	143	264	470
16	750	11	22	23	73	103	185
	1000	16	30	31	83	137	245
	1500	22	45	47	118	206	365
20	750	8	16	19	56	82	150
	1000	11	22	26	69	110	200
	1500	17	33	39	90	165	295
25	750	6	12	14	43	66	120
	1000	8	16	19	54	88	160
	1500	12	24	29	71	132	235

Potencia térmica / Thermal power P_T [kw]

Ratio Ratio i	Tamaño / Size A (mm)					
	2CV-A- 160	2CV-A- 200	2CV-N- 250	2CV-N- 320	2CV-N- 400	2CV-N- 500
6,3...10	32	45	60	75	100	120
12,5...25	22	32	50	75	95	112

DIMENSIONES [mm]
DIMENSIONS [mm]

REDUCTORES
SPEED REDUCER

2CV

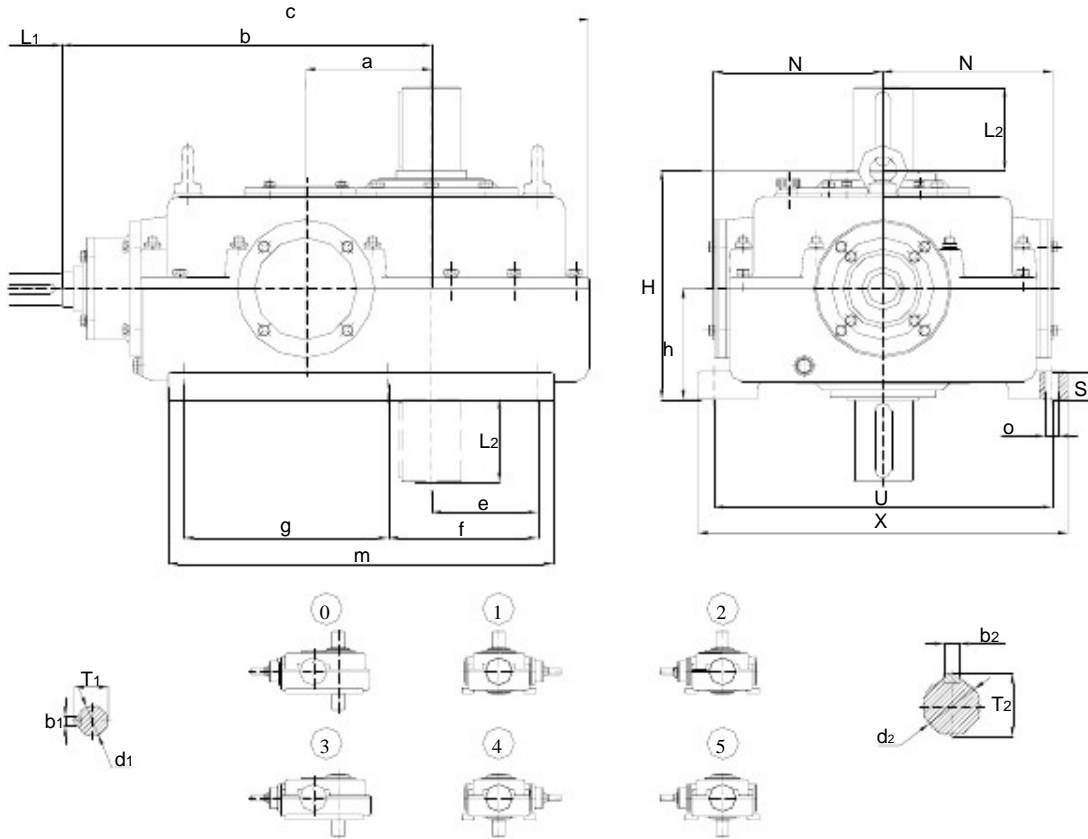

Tamaño Size	a	b	c	e	f	g	h	m	n	o	x	H
2CV-A-160	160	470	755	135	190	260	140	490	430	18	470	290
2CV-A-200	200	575	925	155	250	250	175	600	540	22	600	361
2CV-N-250	250	710	1117	190	305	305	225	680	640	22	700	445
2CV-N-320	320	860	1325	230	390	390	280	880	780	26	850	570
2CV-N-400	400	1040	1625	310	510	510	320	1100	980	33	1060	640
2CV-N-500	500	1310	2025	360	605	605	395	1330	1200	39	1290	795

Tamaño Size	N	S	d ₁	L ₁	b ₁	T ₁	d ₂	L ₂	b ₂	T ₂	Aceite Oil [l]	Peso Weight [kg]
2CV-A-160	216	35	40	82	12	43	75	105	20	79,5	10	190
2CV-A-200	255	40	50	82	14	53,5	95	130	28	104,1	17	296
2CV-N-250	300	60	60	105	18	64,4	95	130	28	104,1	28	600
2CV-N-320	376	60	75	105	20	79,5	120	165	32	127	65	1285
2CV-N-400	485	75	95	130	25	100	160	240	40	169	112	2100
2CV-N-500	580	100	110	165	28	116	200	280	45	210	175	2980

Tolerancias d , D <=30:j6 32..50:k6 >50:m6
Tolerances d , D <=30:j6 32..50:k6 >50:m6

DIMENSIONES [mm]
DIMENSIONS [mm]

REDUCTORES
SPEED REDUCER

2CV

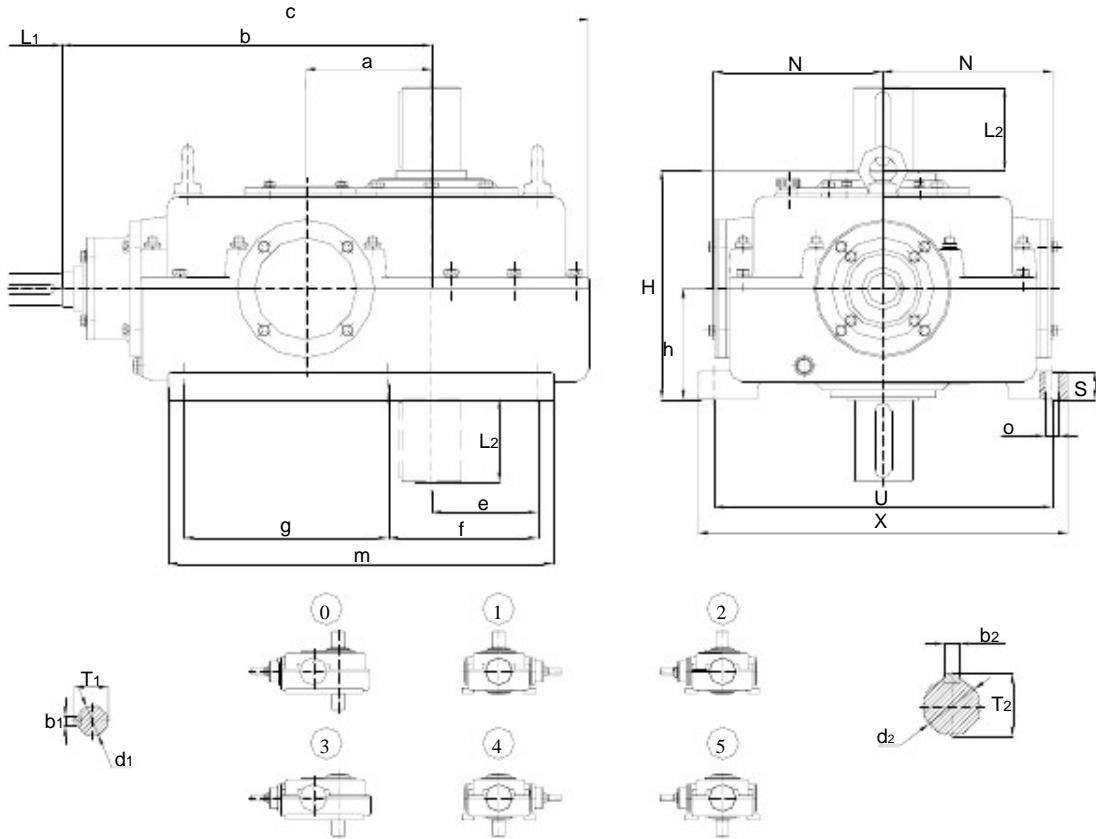

Tamaño Size	a	b	c	e	f	g	h	m	n	o	x	H
2CV-A-160	160	470	755	135	190	260	140	490	430	18	470	290
2CV-A-200	200	575	925	155	250	250	175	600	540	22	600	361
2CV-N-250	250	710	1117	190	305	305	225	680	640	22	700	445
2CV-N-320	320	860	1325	230	390	390	280	880	780	26	850	570
2CV-N-400	400	1040	1625	310	510	510	320	1100	980	33	1060	640
2CV-N-500	500	1310	2025	360	605	605	395	1330	1200	39	1290	795

Tamaño Size	N	S	d ₁	L ₁	b ₁	T ₁	d ₂	L ₂	b ₂	T ₂	Aceite Oil [l]	Peso Weight [kg]
2CV-A-160	216	35	40	82	12	43	75	105	20	79,5	10	190
2CV-A-200	255	40	50	82	14	53,5	95	130	28	104,1	17	296
2CV-N-250	300	60	60	105	18	64,4	95	130	28	104,1	28	600
2CV-N-320	376	60	75	105	20	79,5	120	165	32	127	65	1285
2CV-N-400	485	75	95	130	25	100	160	240	40	169	112	2100
2CV-N-500	580	100	110	165	28	116	200	280	45	210	175	2980

Tolerancias d , D <=30:j6 32..50:k6 >50:m6
Tolerances d , D <=30:j6 32..50:k6 >50:m6

DIMENSIONES [mm]
DIMENSIONS [mm]

REDUCTORES
SPEED REDUCER

3CV

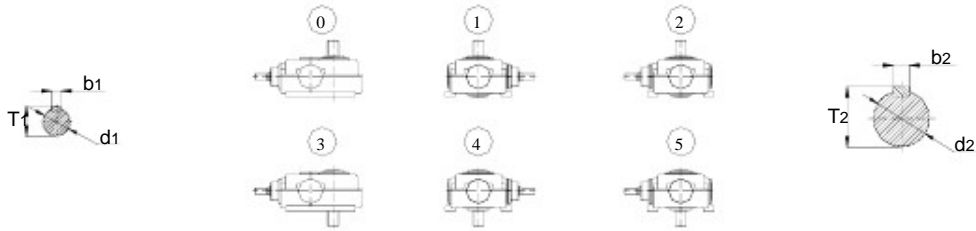
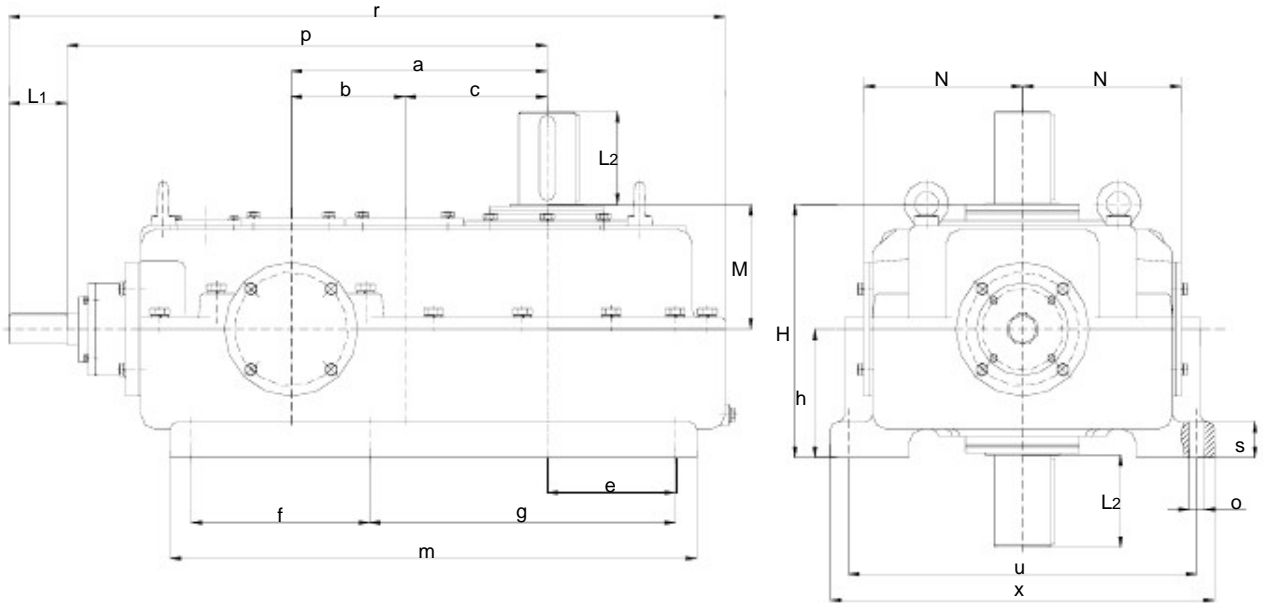

Tamaño Size	a	b	c	r	p	e	f	g	h	s	o	u	m	x
3CV-A-360	360	160	200	1020	675	180	250	430	180	50	22	490	740	540
3CV-A-450	450	200	250	1180	802	215	290	510	200	60	22	580	880	650
3CV-A-570	570	250	320	1510	1030	280	380	640	250	60	26	700	1100	770
3CV-A-720	720	320	400	1881	1280	313	640	714	320	75	33	870	1458	950
3CV-A-900	900	400	500	2235	1540	400	550	1050	400	95	39	1020	1720	1130

Tamaño Size	H	M	N	d1	L1	b1	T1	d2	L2	b2	T2	Aceite Oil [l]	Peso Weight [kg]
3CV-A-360	355	175	250	40	82	12	43	80	130	22	85	35	350
3CV-A-450	410	210	300	50	82	14	53,5	100	165	28	106	65	665
3CV-A-570	505	255	360	60	82	18	65,5	120	165	32	127	105	1040
3CV-A-720	640	320	438	75	105	22	80	160	240	40	169	200	1800
3CV-A-900	800	400	545	90	130	25	95	200	280	45	210	330	3150

Tolerancias d , D<=50:k6 >50:m6
Tolerances d , D<=50:k6 >50:m6