

REDUCTOR MANUAL CONIC PENTRU ARMATURI "MULTITURA" RK - 0.5

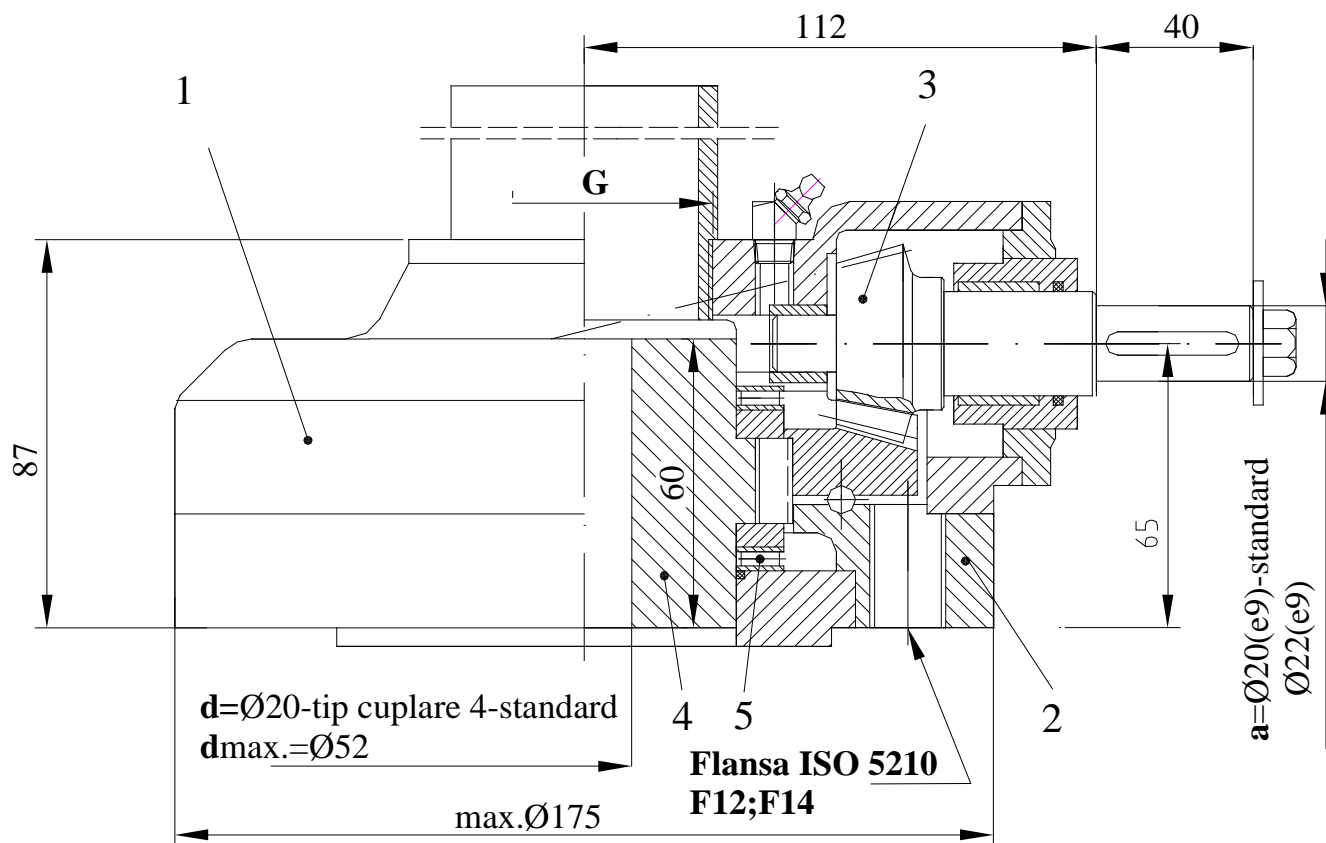

Fisa nr.	456a
Data	22.07.2004

MATERIALE	
1. Carcasa red.conic	OT 450/GS 45
2. Intermediar:	OL 50 /St 50
3. Angrenaj conic:	OLC 45/C45
4. Piulita antrenare:	Cu Al10Fe3T Fagn Ni 22
5. Rulmenti:	ANK 6085

CARACTERISTICI TEHNICE	
• Raport red.conic:	4
• Moment iesire:	500 Nm
• Forta axiala:	120 kN

Raport	Moment intrare (Nm)	D (mm)	Forta tang. pe roata de mana (N)
3,5	179	350	2x512
		400	2x447
		600	2x298
4 standard	156	350	2x446
		400	2x390
		600	2x260

SIMBOLIZARE :

RK 0.5 x 4 - F14 - OB - 20 - 2" - 4 / 20

Tip					d-Dimensiune cuplare pe vana
Raport					d-Tip cuplare pe vana conf. NCI-30
Flansa de cuplare ISO 5210					G-Marime filet aparatoare
OB-Piulita de antrenare Bz -standard					a-Diametru arbore intrare conf. DIN 6885
OF- Piulita de antrenare Fagn Ni 22					

*Roata de mana - A400-standard
A350 ; ; A600
Aparatoare - A60(2")-standard
A70(2 3/8")
Se comanda separat!*

REDUCTOR MANUAL CONIC PENTRU ARMATURI "MULTITURA" RK -2.1

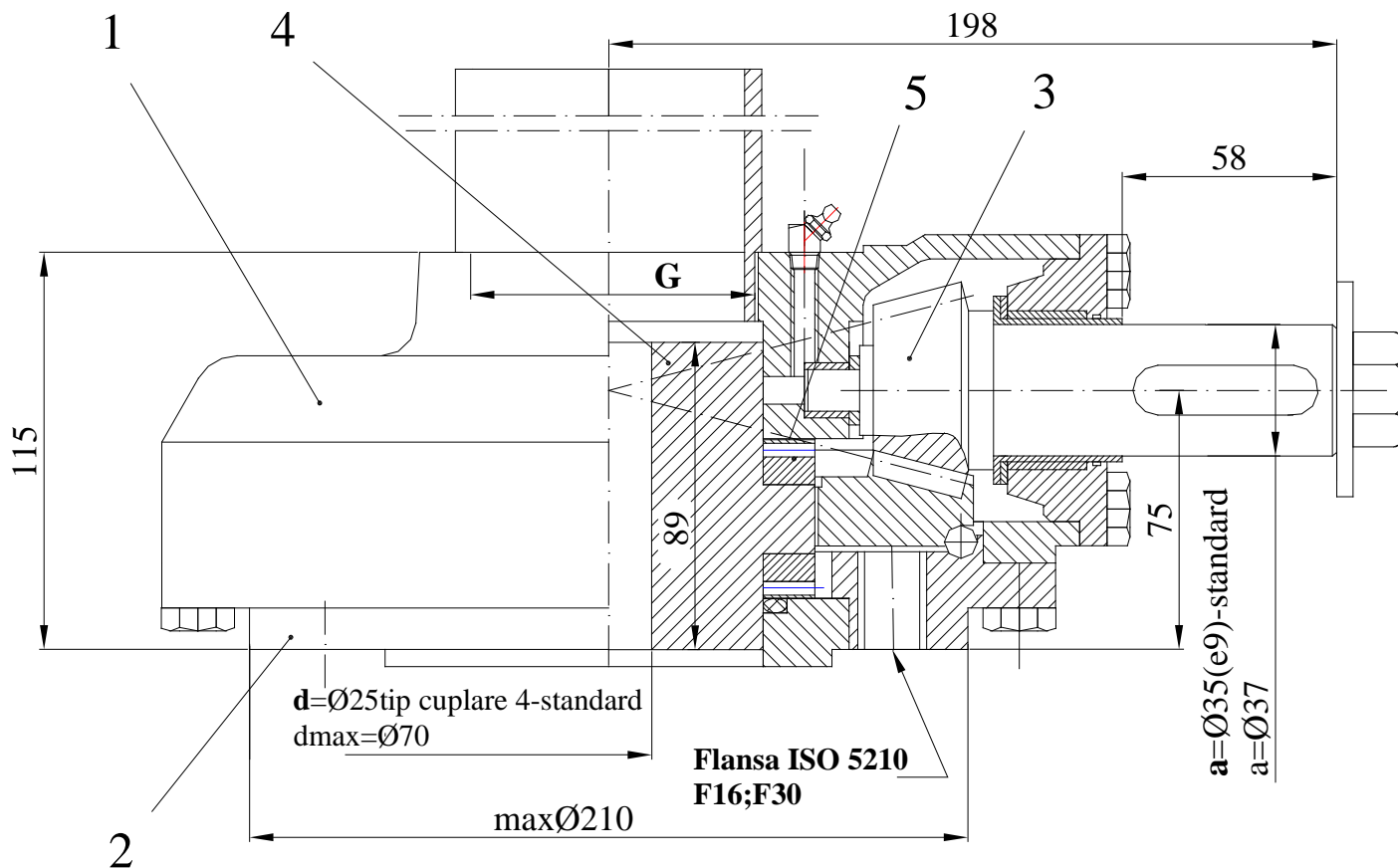

Fisa nr.	464d
Data	01.03.2007

MATERIALE

- 1.Carcasa red.conic: OT 450/GS 45
- 2.Intermediar: OL 50/St 50
- 3.Angrenaj conic: OLC 45 / C45
- 4.Piulita antrenare: Cu Al10 Fe 3T
Fagn Ni 22
- 5.Rulmenti: ANK 90120

CARACTERISTICI TEHNICE

- Raport red.conic: 6
- Moment iesire: 2000 Nm
- Forta axiala: 320 kN

Raport	Moment intrare (N m)	D (mm)	Forta tang.pe roata de mana(N)
6	416	400	2x1040
		600	2x693
		800	2x520

SIMBOLIZARE :

RK 2.1	x	6	-	F16	-	OB	-	35	-	3"	-	4 / 25
Tip												d-Dimensiune cuplare pe vana
Raport												d-Tip cuplare pe vana conf. NCI-30
Flansa de cuplare ISO 5210												G-Marime filet aparatoare
OB- Piulita de antrenare Bz -standard												a-Diametru arbore intrare conf. DIN 6885
OF- Piulita de antrenare Fagn Ni 22												

*Roata de mana – A800-standard
A400 ; A600
Aparatoare – A88,9(3")
Se comanda separat!*

REDUCTOR MANUAL CONIC PENTRU ARMATURI "MULTITURA" RK - 0.15



Fisa nr.	573a
Data	22.07.2004

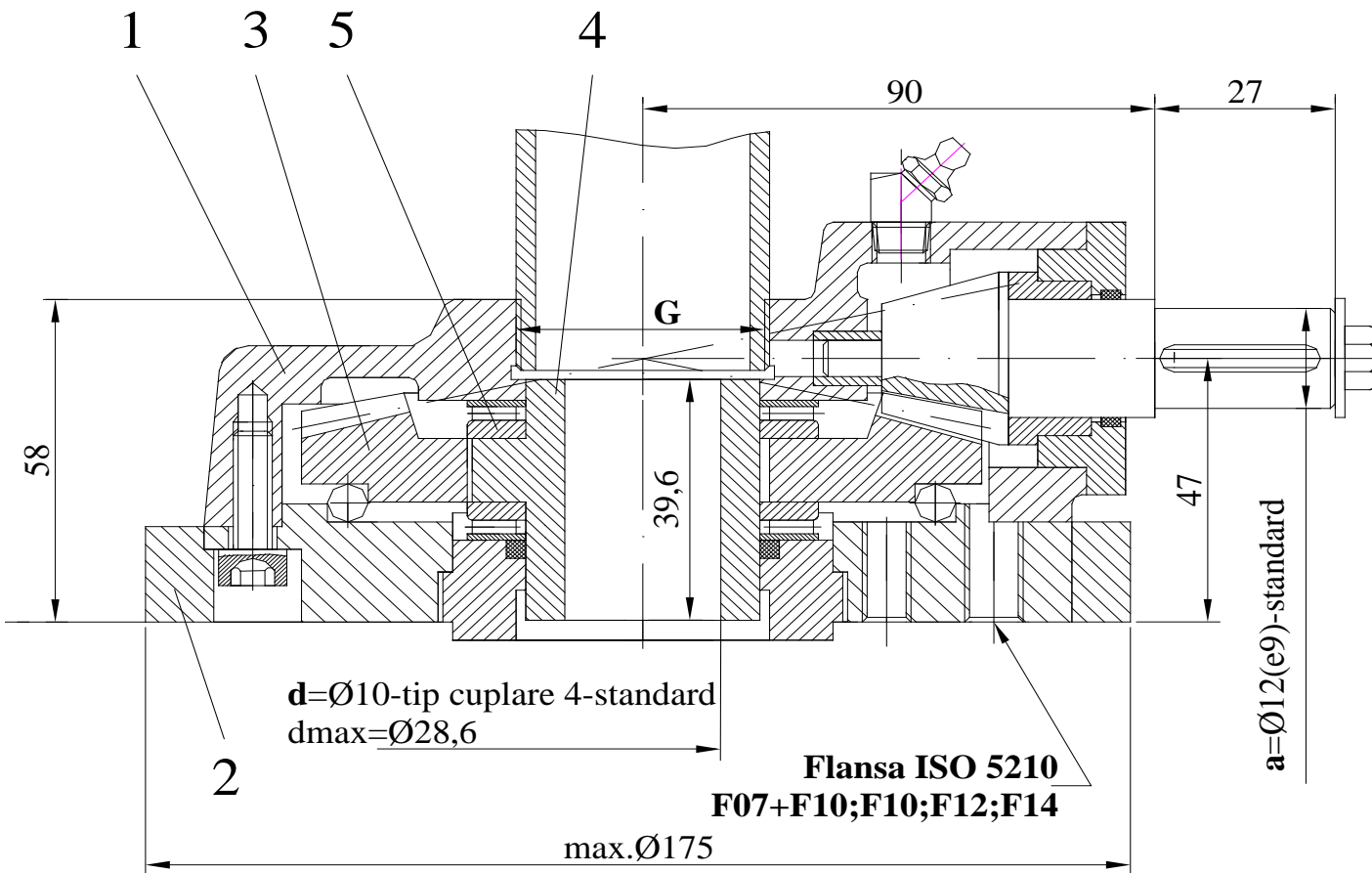

MATERIALE	
1.Carcasa red.conic:	OT 450/GS-45
2.Intermediar:	OL 50/St50
3.Angrenaj conic:	OLC 45 / C 45
4.Piulita antrenare:	CuAl10Fe3T Fagn Ni22
5.Rulmenti:	ANK 3552

CARACTERISTICI TEHNICE	
● Raport red.conic:	4
● Moment iesire:	150 N m
● Forta axiala:	50kN

Raport	Moment intrare (N m)	D (mm)	Forta tang.pe roata de mana (N)
4	47	140	2x334
		225	2x208

SIMBOLIZARE :

RK 0.15	x	4	-	F10	-	OB	-	12	-	1 1/8"	-	4 / 10
Tip												d-Dimensiune cuplare pe vana
Raport												d-Tip cuplare pe vana conf. NCI-30
Flansa cuplare ISO 5210												G-Marime filet aparatoare
OB- Piulita de cuplare B z-standard												a-Diametru arbore intrare conf. DIN 6885
OF- Piulita de antrenare F a g Ni 22												

Roata de mana - ø 225-standard
ø 140
Aparatoare - **A 38(1 1/8")**
Se comanda separat!

REDUCTOR MANUAL CONIC PENTRU ARMATURI "MULTITURA"

RK - 0.2

Fisa nr.	683a
Data	27.07.2004

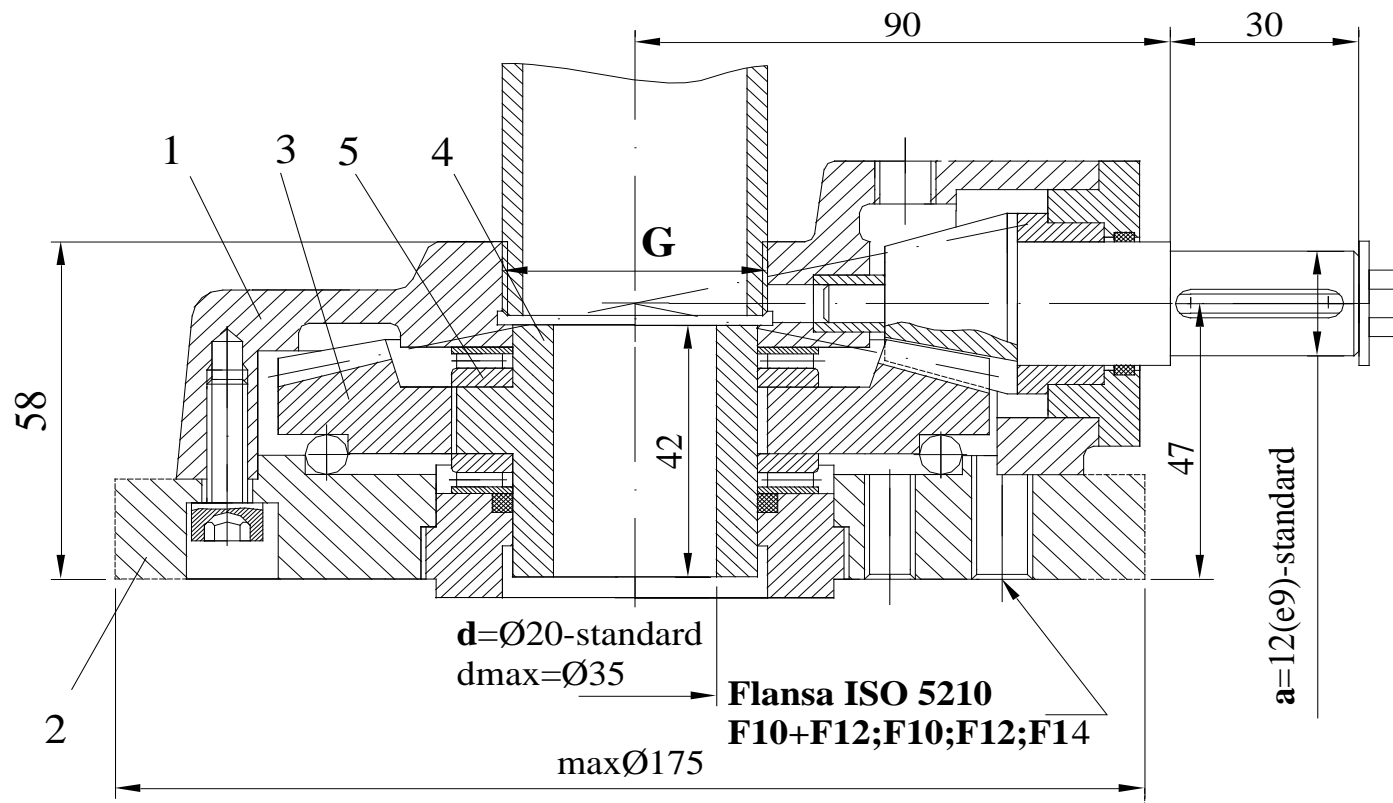

MATERIALE	
1.Carcasa red.conic:	OT 450/GS 45
2.Intermediar:	OLC45/C45
3.Angrenaj conic:	OLC 45 / C 45
4.Piulita antrenare	Cu Al10 Fe 3T
	Fagn Ni 22
5.Rulmenti:	ANK 4565

CARACTERISTICI TEHNICE	
● Raport red.conic:	4
● Moment de iesire:	200 Nm
● Forta axiala:	70kN

Raport	Moment intrare (N m)	D (mm)	Forta tang. pe roata de mana(N)
4	62	225	2x266
		300	2x200

SIMBOLIZARE :

RK 0.2	x	4	-	F14	-	OB	-	12	-	1 1/2"	-	4 / 20
Tip												d-Dimensiune cuplare pe vana
Raport												d-Tip cuplare pe vana conf. NCI-30
Flansa de cuplare ISO 5210								G-Marime filet aparatoare				
OB-Piulita de antrenare Bz -standard								a-Diametru arbore intrare conf. DIN 6885				
OF-Piulita de antrenare Fagn Ni 22												

Roata de mana - ø 300-standard
 ø 225
 Aparatoare - A 48(1 1/2")
 Se comanda separat!

REDUCTOR MANUAL CONIC PENTRU ARMATURI "MULTITURA"

RK - 0.3



Fisa nr.	685 b
Data	03.06.2005

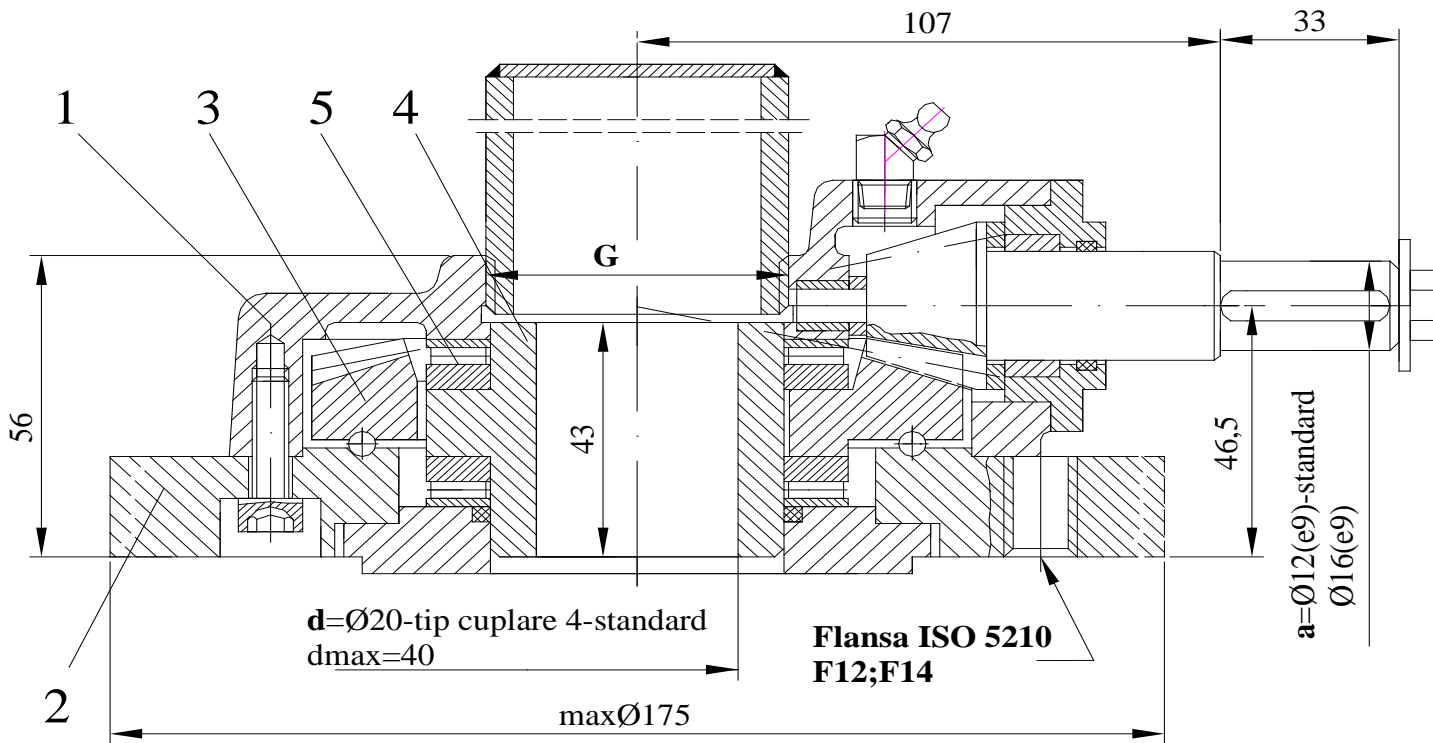

MATERIALS

- 1.Carcasa red.conic : OT 450/GS 45
- 2.Intermediar: OL 50/St50
- 3.Angrenaj conic: OLC 45/C45
- 4.Piulita antrenare: Cu Al10 Fe 3T
Fagn Ni 22
- 5.Rulmenti: ANK 5070

CARACTERISTICI TEHNICE

- Raport red.conic: 4
- Moment de iesire: 300 Nm
- Forta axiala: 70 kN

Raport	Moment de intrare (Nm)	D (mm)	Forta tang.pe roata de mana(N)
4	93	225	2x412
		350	2x265

SIMBOLIZARE :

RK 0.3 x 4 - F14 - OB - 16 - 1 1/2" - 4 / 20

Tip						d-Dimensiune cuplare pe vana
Raport						d-Tip cuplare pe vana conf. NCI-30
Flansa de cuplare ISO 5210						G-Marime filet aparatoare
OB-Piulita de antrenare Bz -standard						a-Diametru arbore intrare conf. DIN 6885
OF- Piulita de antrenare Fagn Ni 22						

Roata de mana -A350 -standard
A225
Aparatoare - A48(1 1/2")
Se comanda separat!

REDUCTOR MANUAL CONIC PENTRU ARMATURI “MULTITURA”

RK - 1

Fisa nr.	742b
Data	27.09.2005

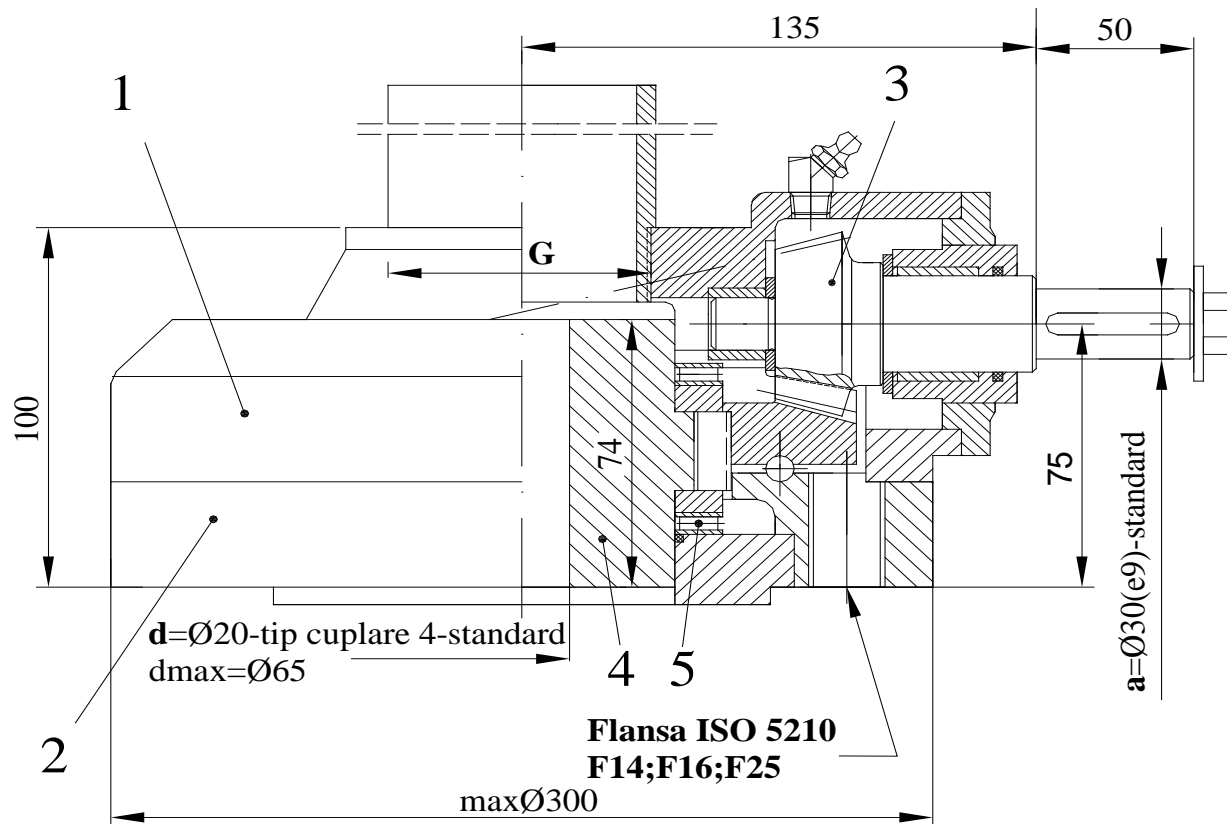

MATERIALS	
1.Carcasa red.conic:	OT 450/GS 45
2.Intermediar:	OL 50/St50
3.Angrenaj conic:	OLC 45/C45
4.Piulita antrenare:	Cu Al10Fe 3T Fagn Ni 22
5.Rulmenti:	ANK 90120

CARACTERISTICI TEHNICE	
● Raport red.conic:	4
● Moment iesire:	1000 Nm
● Forta axiala:	230 kN

Raport	Moment intrare (Nm)	D (mm)	Forta tang.pe roata de mana(N)
4	312	350	2x890
		400	2x780
		600	2x617
6	217	350	2x472
		400	2x540
		600	2x360

SIMBOLIZARE :

RK 1	x	4	-	F16	-	OB	-	30	-	2 3/8"	-	4 / 20
Tip												d-Dimensiune cuplare pe vana
Raport												d-Tip cuplare pe vana conf. NCI-30
Flansa de cuplare ISO 5210												G-Marime filet aparatoare
OB-Piulita de antrenare Bz -standard												a-Diametru arbore intrare conf. DIN 6885
OF- Forta de antrenare Fagn Ni 22												

Roata de mana – A600-standard

A350;A400 ;

Aparatoare – A70(2 3/8)

Se comanda separat!