

P_N [kW]

Verhältnis Ratio i	Drehzahl Eingang Input speed	Grösse / Size A (mm)									
		1H-B- 80	1H-B- 100	1H-B- 125	1H-B- 160	1H-B- 200	1H-B- 250	1H-B- 320	1H-B- 400	1H-B- 500	1H-B- 630
2	750	9,5	20	46	92	135	330	712	1012	2625	2925
	1000	13	27	61	122	180	440	950	1350	3500	3900
	1500	19,5	40,5	91	183	270	660	1425	2025	5250	5850
2,5	750	8	16,5	37,5	78	110	295	500	862	2100	2475
	1000	11	22	50	104	145	395	660	1150	2800	3300
	1500	16,5	33	75	156	220	590	990	1725	4200	4950
3,15	750	6,3	12,5	27	60	92	230	380	725	1515	2250
	1000	8,5	17	36	80	123	305	510	965	2020	3000
	1500	12,5	25,5	54	120	185	455	760	1445	3030	4500
4	750	5,2	10	21	46	81	185	300	575	1132	2025
	1000	7	13,5	28	62	108	245	400	765	1510	2700
	1500	10,5	20	42	93	160	365	600	1145	2265	4050
5	750	3,7	6,7	12,7	27,5	52	97	220	410	825	1650
	1000	5	9	17	37	70	130	290	545	1100	2200
	1500	7,5	13,5	25,5	55	105	195	430	815	1650	3300
6,3	750	2,6	5,2	9	19,5	37	71	155	285	592	975
	1000	3,5	7	12	26	50	95	210	380	790	1300
	1500	5,2	10,5	18	39	75	142	315	570	1185	1950

Thermische Leistung Thermal power P_T (kW)	Verhältnis Ratio i	Grösse / Size A (mm)									
		1H-B- 80	1H-B- 100	1H-B- 125	1H-B- 160	1H-B- 200	1H-B- 250	1H-B- 320	1H-B- 400	1H-B- 500	1H-B- 630
	2	16	25	40	60	85	130	195	290	435	650
	2,5	14	23	35	53	80	115	180	270	405	610
	3,15	12,5	20	32	48	75	105	165	245	365	550
	4	11	18	28	43	65	95	150	225	335	500
	5	10	16	25	38	60	90	140	210	315	470
	6,3	9	14	23	34	53	80	125	195	290	435

Abmessungen [mm]
DIMENSIONS [mm]

GETRIEBE
SPEED REDUCER

1H-B

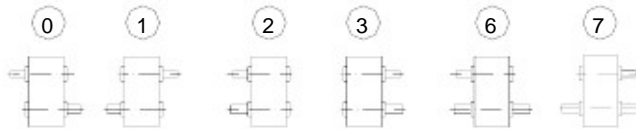
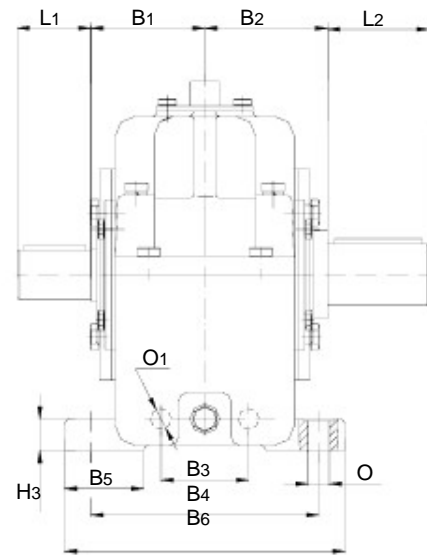
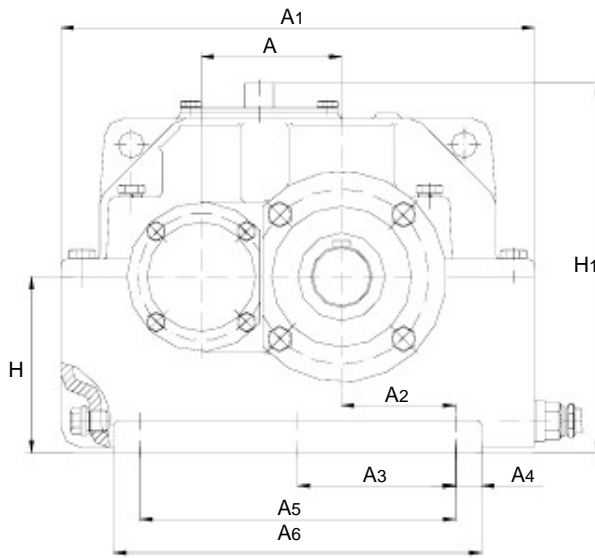

Größe Size	A	A ₁	A ₂	A ₃	A ₄	A ₅	A ₆	B ₁	B ₂	B ₃	B ₄	B ₅	B ₆	H	H ₁	H ₂	H ₃
1H-B-80	80	270	65	-	15	180	210	65	70	-	130	45	160	100	210	18	18
1H-B-100	100	320	85	-	15	230	260	80	85	-	150	50	180	125	255	28	22
1H-B-125	125	405	110	150	25	300	350	106	106	50	205	60	240	160	330	35	25
1H-B-160	160	495	135	180	25	360	410	128	128	80	245	65	280	200	390	35	32
1H-B-200	200	630	145	210	30	420	480	154	154	100	300	80	350	250	480	42	40
1H-B-250	250	760	180	260	40	520	600	175	190	100	350	100	400	315	590	40	50
1H-B-320*	320	940	290	390	50	780	880	230	230	160	450	110	520	400	750	35	60
1H-B-400*	400	1150	370	485	50	970	1070	250	250	230	500	110	580	500	930	55	70
1H-B-500*	500	1455	400	550	75	1100	1250	300	320	220	600	250	700	550	1076	45	40
1H-B-630*	630	1675	320	550	75	1100	1250	390	390	380	600	200	700	710	1395	85	40

Größe Size	O	O ₁	d ₁	L ₁	b ₁	T ₁	d ₁	L ₁	b ₁	T ₁	d ₂	L ₂	b ₂	T ₂	Öl Oil [l]	Gewicht Weight [kg]
			i=2÷4				i= 4,5 ÷ 6,3									
1H-B-80	-	12	28	42	8	31	22	36	6	24,5	35	58	10	38	1,5	27
1H-B-100	-	10	32	58	10	35	25	42	8	28	45	82	14	48,5	2	48
1H-B-125	14	21	42	82	12	45	30	58	8	33	55	82	16	59	5	75
1H-B-160	14	21	50	82	14	53,5	40	82	12	43	75	106	20	79,5	8,5	160
1H-B-200	18	25	65	105	18	64	50	82	14	53,5	95	131	25	100	18	250
1H-B-250	22	25	85	130	22	90	70	106	20	74,5	110	165	28	116	35	480
1H-B-320*	33	25	100	165	28	100	90	132	25	95	130	202	35	137	72	780
1H-B-400*	33	25	125	165	32	132	110	165	28	116	170	242	40	179	130	1425
1H-B-500*	39	24	160	240	40	179	130	200	32	137	200	280	45	210	285	2530
1H-B-630*	39	30	130	200	32	137	130	200	32	137	200	280	45	210	400	3599

Toleranzen d₁, d₂ ≤30:j6 32..50:k6 >50:m6
Tolerances d₁, d₂ ≤30:j6 32..50:k6 >50:m6

* Gehäuse aus geschweißtem Stahl

NENNLEISTUNGEN
NOMINAL POWERS

GETRIEBE
SPEED REDUCER

2H-B

P_N [kW]

Verhältnis Ratio i	Drehzahl Eingang Input speed	Grösse / Size A (mm)							
		2H-B- 205	2H-B- 260	2H-B- 325	2H-B- 410	2H-B- 520	2H-B- 650	2H-B- 820	2H-B- 1030
8	750	8	16	36,8	83	150	275	500	1000
	1000	11	21	49	110	200	365	700	1380
	1500	16,5	31,5	73	165	300	540	1000	2100
10	750	7,1	13,9	33	67	125	230	400	720
	1000	9,5	18,5	44	90	165	305	500	1000
	1500	14,2	27,5	66	135	245	450	800	1480
12,5	750	5,5	12,4	25,5	52	97	180	330	630
	1000	7,5	16,5	34	70	130	240	400	850
	1500	11,2	24,1	51	105	195	355	630	1330
16	750	4,8	10	20	41	75	150	250	500
	1000	6,5	13,5	27	55	100	200	350	690
	1500	9,7	20,2	40	82	150	295	500	1020
20	750	3,4	7,5	13,5	25,5	55	105	200	360
	1000	4,5	9	18	34	75	140	250	500
	1500	6,7	13,5	27	51	109	200	400	740
25	750	2,5	5,6	10,5	20,5	45	80	160	320
	1000	3,5	7,5	14	27	60	110	200	410
	1500	5,2	11,2	21	40,5	90	160	320	655
31,5	750	2	4,2	8,2	16,5	37,5	65	130	250
	1000	2,8	5,5	11	22	50	85	175	345
	1500	4,2	8,2	16,5	33	75	130	255	520
40	750	1,5	3,4	6	12	25,5	45	91	185
	1000	2	4,5	8	16	35	60	120	250
	1500	3	6,7	12	24	50	85	180	370

Thermische Leistung Thermal Power P_T (kW)	Verhältnis Ratio i	Grösse / Size A (mm)							
		2H-B- 205	2H-B- 260	2H-B- 325	2H-B- 410	2H-B- 520	2H-B- 650	2H-B- 820	2H-B- 1030
	8	18	30	50	70	110	180	285	430
	10	17	28	42	68	105	175	275	415
	12,5	16,5	27	41	65	100	170	270	405
	16	16	26	39	62	95	160	255	380
	20	15,5	25	38	61	93	155	250	370
	25	15	25	37	59	90	135	245	367
	31,5	14	24	36	57	88	130	200	310
	40	13	22	35	56	81	125	185	278

ABMESSUNGEN [mm]
DIMENSIONS [mm]

GETRIEBE
SPEED REDUCER

2H-B

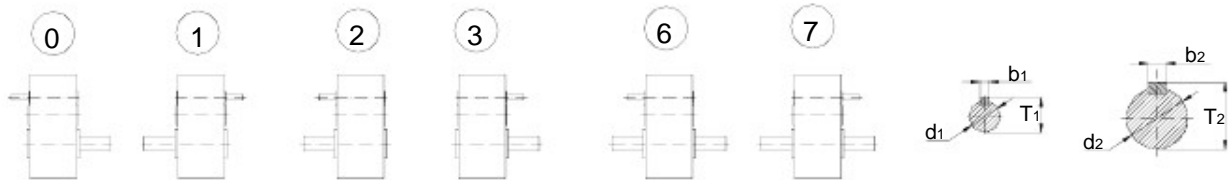
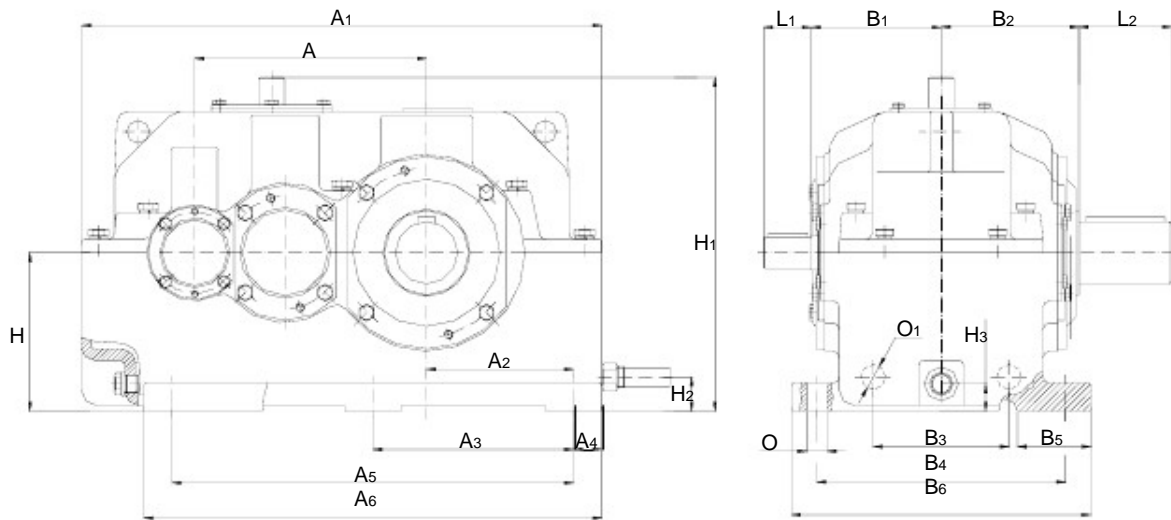

Grösse Size	A	A ₁	A ₂	A ₃	A ₄	A ₅	A ₆	B ₁	B ₂	B ₃	B ₄	B ₅	B ₆	H	H ₁	H ₂	H ₃
2H-B-205	205	460	130	-	25	355	405	115	122	120	220	-	265	140	290	30	25
2H-B-260	260	560	165	225	25	450	500	145	150	132	265	65	315	200	388	40	35
2H-B-325	325	725	150	250	50	500	600	167	185	120	350	90	400	250	470	40	40
2H-B-410*	410	870	210	330	42	660	720	210	230	-	420	140	480	280	555	-	46
2H-B-520*	520	1085	285	410	35	820	975	275	283	240	540	162	615	400	750	44	30
2H-B-650*	650	1340	370	540	50	1080	1180	298	340	240	630	172	700	500	930	69	35
2H-B-820*	820	1675	415	645	80	1290	1510	377	400	280	770	230	880	630	1160	75	40
2H-B-1030*	1030	1980	425	700	290	1400	1837	450	450	-	900	250	1000	710	1390	-	35

Grösse Size	O	O ₁	i = 8 ÷ 16				i = 20 ÷ 40				d ₂	L ₂	b ₂	T ₂	Öl Oil [l]	Gewicht Weight [kg]
			d ₁	L ₁	b ₁	T ₁	d ₁	L ₁	b ₁	T ₁						
2H-B-205	18	22	28	42	8	31	22	36	6	24,5	55	82	16	59,3	4	88
2H-B-260	18	22	32	58	10	35	25	42	8	28	75	105	20	79,5	7	160
2H-B-325	22	25	42	82	12	45	30	58	8	33	95	130	25	100	20	340
2H-B-410*	26	-	50	82	14	53,5	40	82	12	43	110	165	28	116	30	519
2H-B-520*	33	26	65	105	18	69	50	82	14	53,5	130	200	32	137	45	1040
2H-B-650*	33	26	85	130	22	90	70	105	20	74,5	170	240	40	179	130	1673
2H-B-820*	39	25	100	165	28	100	90	130	25	94	200	280	45	210	200	2450
2H-B-1030*	39	-	95	165	25	100	95	165	25	100	240	330	56	252	550	4850

Toleranzen d₁, d₂ <=30:j6 32..50:k6 >50:m6
Tolerances d₁, d₂ <=30:j6 32..50:k6 >50:m6

* Gehäuse aus geschweißtem Stahl

P_N [kW]

Verhältnis Ratio i	Drehzahl Eingang Input speed	Grösse / Size A (mm)					
		3H-B- 405	3H-B- 510	3H-B- 645	3H-B- 810	3H-B- 1020	3H-B- 1280
40	750	6,5	13,5	28,5	54	100	180
	1000	8	18	38	72	130	220
	1500	12,5	26,6	52	106	195	360
50	750	5,2	12,4	24	48	80	150
	1000	7	16,5	32	65	106	200
	1500	10,5	24,5	48	97	160	310
63	750	4,5	10	19,5	39	70	135
	1000	6	13,5	26	52	73	180
	1500	9	20,2	39	78	140	270
80	750	3,3	6,3	14,2	27	55	95
	1000	4,5	8,5	19	36	73	120
	1500	6,7	12,7	28,5	54	110	190
100	750	2,6	4,8	11,2	20	43	80
	1000	3,5	6,5	15	27	58	100
	1500	5,2	9,7	22,5	40	87	170
125	750	2,2	4,1	9	18,5	35	78
	1000	3	5,5	12	25	46	92
	1500	4,5	8,2	18	37,5	70	140
160	750	1,8	3,3	7	14,2	27	55
	1000	2,5	4,5	9,5	19	36,5	70
	1500	3,7	6,7	14,2	28,5	55	110
200	750	1,5	2,6	5,5	11,2	22	40
	1000	2	3,5	7,5	15	30	58
	1500	3	5,2	11,2	22,5	45	80

	Verhältnis Ratio i	Grösse / Size A (mm)					
		3H-B- 405	3H-B- 510	3H-B- 645	3H-B- 810	3H-B- 1020	3H-B- 1280
Thermische Leistung Thermal power	40	29	43	65	103	166	260
	50	28	43	63	100	160	256
P_T (kW)	63	27	42	61	98	155	247
	80	27	41	60	96	155	245
	100	26	40	59	95	150	225
	125	26	39	58	93	145	220
	160	25	38	57	91	145	215
	200	25	37	56	90	140	210

ABMESSUNGEN [mm]
DIMENSIONS [mm]

GETRIEBE
SPEED REDUCER

3H-B

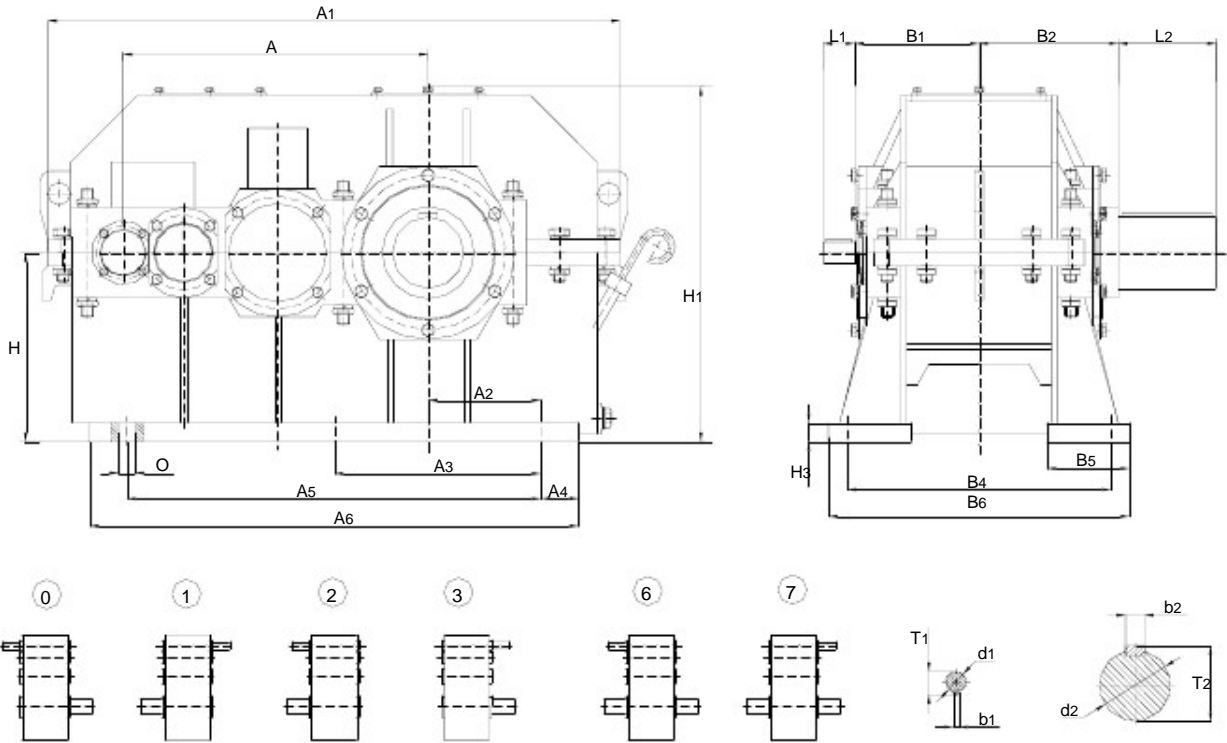

Grösse Size	A	A ₁	A ₂	A ₃	A ₄	A ₅	A ₆	B ₁	B ₂	B ₄	B ₅	B ₆	H	H ₁	H ₃
3H-B-405*	405	755	150	275	50	550	650	165	185	350	110	400	250	470	25
3H-B-510*	510	922	210	370	30	740	838	206	230	420	130	480	280	555	35
3H-B-645*	645	1215	285	410	50	820	920	275	283	540	155	610	400	740	30
3H-B-810*	810	1430	355	620	37	1240	1314	300	340	630	170	700	400	805	40
3H-B-1020*	1020	1818	415	751	80	1502	1662	370	400	770	250	880	630	1150	55
3H-B-1280*	1280	2200	425	850	175	1700	2060	435	450	700	145	800	710	1400	35

Grösse Size	O	i = 31,5 ÷ 63			i = 80 ÷ 200			d ₂	L ₂	b ₂	T ₂	Öl Oil [l]	Gewicht Weight [kg]		
		d ₁	L ₁	b ₁	T ₁	d ₁	L ₁							b ₁	T ₁
3H-B-405*	22	28	42	8	31	22	36	6	24,5	95	130	25	100	30	290
3H-B-510*	26	32	58	10	35	25	42	8	28	110	165	28	116	60	490
3H-B-645*	33	42	82	12	45,3	30	58	8	33,3	130	200	32	137,4	200	820
3H-B-810*	35	50	82	14	53,5	40	82	12	45	170	240	40	179	120	1690
3H-B-1020*	39	65	105	18	69	50	82	14	54	200	280	45	210	350	2580
3H-B-1280*	33	75	105	20	79,5	60	105	18	64	240	330	56	252	600	6500

Toleranzen d₁, d₂ ≤30:j6 32..50:k6 >50:m6
Tolerances d₁, d₂ ≤30:j6 32..50:k6 >50:m6

* Gehäuse aus geschweißtem Stahl